

HUCK® INTERACTIVE CD ROM : SPECIFICATIONS

2580

2580 Hydraulic Installation Tool

Specifications

Weight:

2.98 (6.58 lbs.)

Stroke:

24 mm (0.94")

Operating Hydraulic Pressures:

Pull- *max 393 bar (*5700 psi)

Return-221 bar (3,200 psi)

* For fastener diameter 9.5 mm (3/8")
and above use 510 bar (7400 psi)

Capacity:

36,65 kN @ 393 bar

(8240 lbs @ 5700 psi)

47,6 kN @ 510 bar

(10700 lbs @ 7400 psi)

Part of the FOCUS Tooling Range

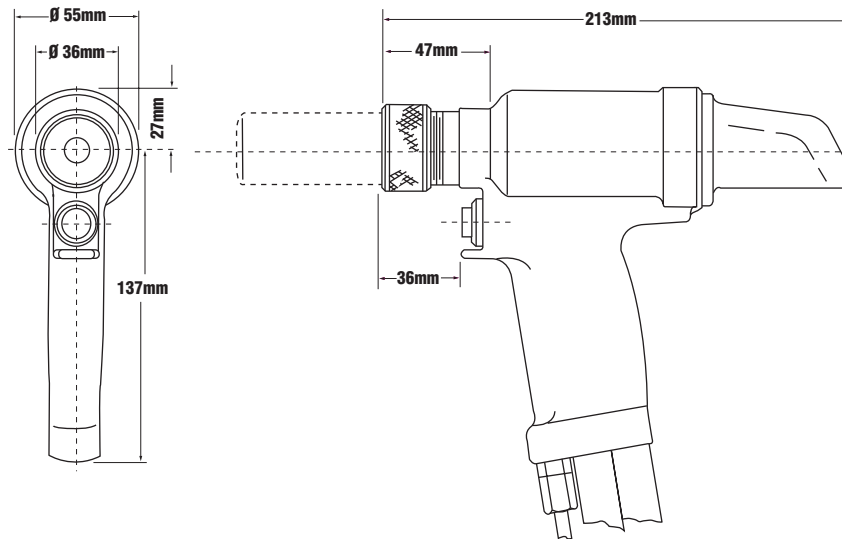

HUCK® INTERACTIVE CD ROM : NOSE ASSEMBLY TABLE

2580

Some Fasteners & Nose Assemblies for use with the 2580 Tool

| Type | Diameter | Nose Assembly |
|------------|---------------------------|-------------------|
| BOM | 4.8 mm ($\frac{3}{16}$ " | 99-1053 |
| | 6.4 mm ($\frac{1}{4}$ " | 99-830-1 |
| | 7.9 mm ($\frac{5}{16}$ " | 99-769 |
| | 9.5 mm ($\frac{3}{8}$ " | 99-1272 |
| MAGNA-LOK | 9.5 mm ($\frac{3}{8}$ " | 99-3318 |
| MAGNA-BULB | 7.9 mm ($\frac{5}{16}$ " | 99-3307 |
| C6L/C120L | 4.8 mm ($\frac{3}{16}$ " | 99-2558 |
| | 6.4 mm ($\frac{1}{4}$ " | 99-2564 |
| | 7.9 mm ($\frac{5}{16}$ " | 99-99-245 |
| | 9.5 mm ($\frac{3}{8}$ " | 99-100-245 |
| MAGNA-GRIP | 4.8 mm ($\frac{3}{16}$ " | 99-3206 |
| | 6.4 mm ($\frac{1}{4}$ " | 99-3207 |
| | 7.9 mm ($\frac{5}{16}$ " | 99-1439 |
| | 9.5 mm ($\frac{3}{8}$ " | 99-1440 |
| HUCKTAINER | 9.5 mm ($\frac{3}{8}$ " | 99-3438 |

Items in **bold** are part of our FOCUS Tooling Range